



# Brochure and manual



**Windvane self steering**

*Freedom with a Vee*

January 2023

**Copyright 2015-2023**

No part of this document may be reproduced, altered or used for commercial purposes without written permission from Mister Vee.

# About this documentation

Mister Vee manufacture windvane self steering systems and replacement parts for Navik self steering systems.

These products are offered through the Mister Vee website.

The more in depth information on self steering as a means to keep a boat on course and the systems on offer is now in front of you.

## Links to the [Mister Vee website \(link\)](#)

If you read this document as a pdf, you can directly access pages and documents on the Mister Vee website if “(link)” is written behind a word.

### **Text in a frame**

If you see text in a frame, it is meant as essential, please take that information to heart!

### **Text in a grey box**

When you see text in a grey box, it is meant as a deeper level of information, which may not be relevant at first.

### **Images**

Images in this documentation have been collected through the years and may show configurations that have since then been changed.

January 26, 2023

# Contents

<b>Brochure and manual.....</b>	<b>1</b>
<b>About this documentation.....</b>	<b>3</b>
<b>WARNING.....</b>	<b>8</b>
<b>Section 1:.....</b>	<b>9</b>
<b>Why choose Mister Vee?.....</b>	<b>9</b>
Mister Vee self steering in short:.....	9
The goal of Mister Vee.....	9
Does a small budget suit you?.....	9
Small or big boats?.....	10
Low weight.....	10
Super sensitive.....	11
“Your boat dictates where the holes go”.....	11
<b>Bonuses in the Mister Vee designs.....</b>	<b>11</b>
Bonuses in the Mister Vee designs.....	11
Up Side Down Windvane.....	11
Theft prevention.....	12
Overload protection.....	12
<b>Why use windvane self steering?.....</b>	<b>13</b>
Why use windvane self steering?.....	13
Be Vree from the helm!.....	13
How does windvane self steering compare to autopilots?.....	13
Smooth course keeping.....	14
No power consumption.....	14
Quiet.....	14
<b>Section 2:.....</b>	<b>16</b>
<b>Setting up self steering.....</b>	<b>16</b>
How does windvane self steering work?.....	17
But what's the point of all this?.....	17
Better steering.....	17
Isn't this a bit over complicated?.....	17
Requirements for windvane self steering.....	19
Self steering needs a well balanced boat.....	19
Wind.....	19

Low friction.....	19
Wheel Steering.....	19
Wheel Steering+emergency tiller.....	19
Space on the transom.....	20
Space above the transom.....	20
Multi hull's and ULD boats?.....	20
<b>Mounting the system.....</b>	<b>21</b>
Mounting the system.....	21
Requirements.....	21
Mounting height.....	21
On the center line.....	22
Swim ladder & other gear.....	22
Steering lines.....	22
Setting up the steering lines.....	24
Special rudder heads.....	26
Alternative path for the steering lines.....	26
Wheel steering.....	26
Mounting in the water or on the hard?.....	27
<b>Section 3:.....</b>	<b>28</b>
<b>Choosing your Mister Vee self steering system.....</b>	<b>28</b>
Mounting your Mister Vee self steering system.....	28
Mounting solutions overview.....	29
Length of the mounting tubes.....	31
<b>3.1 Mister Vee systems comparison.....</b>	<b>31</b>
3.1 Mister Vee systems comparison.....	31
Y&B Round 30 & 90: Standard mounting (link).....	33
Y&B Round CA (link).....	33
Y&B Wide 90 & Wide CA.....	33
y&b round & wide in short:.....	34
Y&B variable (link).....	35
Y&B variable in short:.....	36
Y&B Stretch (link).....	38
Y&B KIT (link).....	39
Plywood pendulum rudder.....	39
Epoxy foam pendulum rudder.....	39
Dimensional drawing (link).....	40
<b>Section 4:.....</b>	<b>41</b>

<b>Using windvane self steering.....</b>	<b>41</b>
<b>IMPORTANT.....</b>	<b>42</b>
Considerations on using self steering.....	42
Practice before you really need it.....	42
Proper trim.....	42
Locked windvane equals locked system.....	42
Moving boat.....	43
Reversing the boat.....	43
Pendulum rudder angle.....	43
Counterweight.....	43
<b>Big forces at play.....</b>	<b>44</b>
<b>4.1 Operating the system.....</b>	<b>46</b>
4.1 Operating the system.....	46
Before you leave.....	46
Connecting the pendulum rudder.....	46
First trials.....	46
Setting course.....	47
Changing course.....	48
Changing course without changing tack.....	48
Tacking or gybing.....	48
<b>4.2 Routine maintenance.....</b>	<b>49</b>
4.2 Routine maintenance.....	49
Loose nuts and bolts.....	49
Bearings.....	49
Mast.....	49
Pendulum rudder blade.....	50
Steering lines.....	51
Cleaning the system.....	51
<b>4.3 Trouble shooting.....</b>	<b>52</b>
4.3 Trouble shooting.....	52
The terms we use when trouble shooting.....	53
Mast rotation.....	53
Windvane axis change.....	53
Windvane swing.....	53
Pendulum rudder rotation.....	53
Pendulum swing.....	54
Problems and solutions.....	54

The boat steers a zig-zag course (oversteering).....54  
Friction may occur in these points:.....55  
Pendulum rudder stays at the waters surface/does not go down.....56  
Pendulum rudder flotation.....57  
The boat is constantly turning slowly in to the wind. .58  
Pendulum tracking: The pendulum rudder is not in neutral when the boat is moving forward.....58  
Pendulum tracking & Propwash during motoring.....59  
Readjusting the pendulum rudder to track better.....59  
Still not tracking?.....60  
The windvane is not neutral whilst steering.....60  
Altered pushrod.....60  
The pendulum rudder keeps separating from the system.....61  
**Mister Vee Windvane self steering.....62**  
**Freedom with a Vee.....62**



Be Vree from the helm!

# WARNING

**A self steering system can not see or judge a situation.**

No matter what kind of self steering system is used, the boats skipper is always responsible for the safety of the boat and it's occupants!

**While using a self steering system you must always be ready to disconnect the system and steer the boat manually.**



# Section 1:

## Why choose Mister Vee?

### **Mister Vee self steering in short:**

- The lightest self steering
- The best course keeping
- Available for just about any transom
- Budget friendly

When you sail longer trips, especially when you sail solo or with a very small crew, keeping the boat at the correct angle to the wind needs constant attention. This is fun for about half an hour, after that it becomes a boring nuisance.

If you feel that you have better things to do than steering the boat continuously then windvane self steering might be the thing for you.

### **The goal of Mister Vee**

Mister Vee has its roots in small boat sailing. Small boats are often sailed with small budgets and benefit greatly from low weight self steering.

Budget friendliness and light weight is in the the Mister Vee dna.

### **Does a small budget suit you?**

Boaty things get expensive quickly. The quantities made are small and the demands are big.

So lets be clear on pricing first.

When Mister Vee mean affordable, that does not mean “cheap”.

Cheap usually means cutting corners, affordable means making choices, sometimes difficult ones.

Some of the choices during development made for the very unique systems now on offer.

These are not the cheapest but are still at the affordable end of the spectrum.

The Mister Vee self steering systems are probably the ones that start steering with the least amount of wind thus giving the best off wind performance and they are definitely the lightest, by a very big margin.

And if your boat has an even slightly more demanding mounting situation, both affordability and light weight lean towards Mister Vee even more.

### **Small or big boats?**

Thanks to design- and material choices Mister Vee systems offer affordability and unmatched light weight.

That makes Mister Vee the prime choice for smaller boats. But what about bigger boats?

Rule of thumb:

If you can steer the boat without fighting the rudder, so can a Mister Vee servo pendulum system. No matter if the boat is 15 feet or 36 feet or even larger. (Exception: Hydraulic steering)

### **Low weight**

Saving weight at the ends of a boat benefits performance in

waves.

From the start, the Mister Vee design process was aimed at just that: saving weight.

This is primarily achieved by utilizing the same materials as are used in Formula 1 race cars and ocean racing sail boats: Glass fiber- and carbon fiber/epoxy.

### **Super sensitive**

Because of the lower overall weight and clever design, Mister Vee can utilize super low friction bearings. By using these in almost all wind driven axis, the Mister Vee self steering systems are possibly the most sensitive systems around. This results in a system that starts steering with very little wind, even if the wind comes from behind!

### **“Your boat dictates where the holes go”**

A self steering system is mounted to the boats transom and holes need to be drilled for that.

Mister Vee offer mounting solutions that allow (if needed) to choose where to drill these holes based on accessibility on the inside of the transom.

## **Bonuses in the Mister Vee designs**

### **Up Side Down Windvane**

Mister Vee is the first and only company to offer systems with a windvane blade that rotates underneath its axis. Why is this important?

On down wind courses with little heel a normal vane has maximum steering ability which is mostly not necessary and can easily cause over steering. Up Side Down (USD)

windvanes are better suitable for down wind courses: they prevent oversteering. This discovery was made by Netherlands wind vane steering expert Jan Alkema who published his findings in sailing magazines and on the internet.



Jan Alkema Looking at the Mister Vee version of his USD windvane concept

At just 1260 grams the complete windvane is lighter than most competitors windvane-counter weight!

### **Theft prevention**

Both the windvane and the pendulum rudder can be easily removed from the system. These are the most valuable bits that can then be stored inside the boat.

### **Overload protection**

The mechanism that lets you disconnect the pendulum rudder also releases when it is struck by something in the water.

## **Why use windvane self steering?**

When you take longer trips, especially when you sail solo or with a very small crew, keeping the boat at the correct angle to the wind needs constant attention. This is fun for about half an hour, after that it becomes a boring nuisance.

### **Be Vree from the helm!**

Self steering from Mister Vee keeps your boat at the correct angle to the wind so you can:

- Get something to drink or prepare a meal
- Navigate
- Put in a reef
- Hoist the sails while motoring in to the wind
- Change the sails
- Do small repairs
- Look around and enjoy your sailing!

Once you have experienced windvane self-steering from Mister Vee, your sailing will never be the same again!

### **How does windvane self steering compare to autopilots?**

In essence, a servo pendulum windvane self steering system is the same as an autopilot.

Both move the boats main rudder when some kind of change is detected in the boats course.

With a windvane that is a change in apparent wind direction, with an autopilot that is a change in the compass course.

## **So why choose one way over another?**

The main 2 reasons to choose a wind vane self steering system over an autopilot are these:

Quality of course keeping & no power consumption.

### **Smooth course keeping**

A windvane self steering system steers continuously. The smallest of changes in the apparent wind direction get picked up and are acted upon. With an autopilot there needs to be a specific deviation before it starts to correct. In practice this means that a windvane steers in a smoother way with less zigging and zagging.

### **No power consumption**

If you run a boat that has a freezer and a radar, chances are you have a way to keep the batteries full. In that case, adding an autopilot does not increase the daily power consumption dramatically.

But if you like a more minimalist approach, chances are you have a relatively small battery and minimal ways to keep it full. In that case, using an autopilot on a longer trip with a bit of a breeze may empty your battery in just one day.

With more wind, the power consumption goes up. If you want to add means to charging the battery on the go, the total cost of adding autopilot self steering comes very close to the cost of windvane self steering. With windvane self steering, the steering ability gets better and better when the wind picks up where as an auto pilot will have more and more trouble.

## **Quiet**

Oh, and there is a third reason. When an autopilot is working it makes a lot of noise. A windvane self steering system works quietly. All the time. Effortless.

It's a sailing thing.

# Section 2:

## Setting up self steering

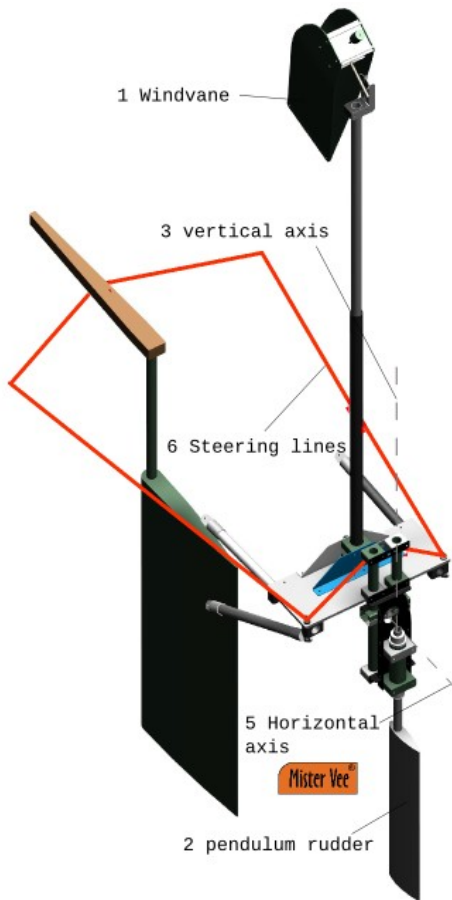



## **How does windvane self steering work?**

All Mister Vee self steering systems are of the servo pendulum type. This is how they work:

- The wind moves the windvane (1)
- That makes the pendulum rudder (2) rotate around its vertical axis (3)
- The water flowing past the pendulum rudder makes it swing sideways around its horizontal axis (5)
- Steering lines (6) that are connected to the pendulum rudder and the boats main rudder make the boat steer back to the correct course, the windvane returns to neutral.

## **But what's the point of all this?**

Isn't there an easier and better way to keep the boat on course?

No!

## **Better steering**

No electronic device or other windvane self steering principle can match a servo-pendulum system in the quality of course keeping!

Due to some clever design by Mister Vee it was possible to use ball bearings in every wind driven axis, resulting in a very low friction in the transmission of the movement of the windvane. This means that our systems can steer your boat with less wind than any other system, on any course.

## **Isn't this a bit over complicated?**

If the pendulum rudder couldn't swing side to side it would still steer the boat, wouldn't it?

Well, yes and no.

It would result in a basic steering action. But to actually keep a boat on course you would need a much larger rudder which would require a fortified connection to the boat. But the resulting steering would be nowhere near as accurate a servo pendulum can achieve.

Servo pendulum systems from Mister Vee give the best wind steering action.



## **Requirements for windvane self steering**

If you are interested in setting up windvane self steering on your boat, keep the following in mind:

### **Self steering needs a well balanced boat**

If you have to fight the tiller to keep the boat on course a self steering system will have trouble too.

### **Wind**

Obviously you will need wind for the system to steer your boat. As the system uses the apparent wind a running course will need more true wind than a close hauled course.

### **Low friction**

The lower the friction is in the total system, including the boats rudder, the earlier it will steer in light airs especially on running courses. Low friction is a specialty of the Mister Vee systems!

The need for low friction means that hydraulic steering will not work. Only a system with an auxiliary rudder could work here.

### **Wheel Steering**

If your boat has wheel steering you will probably need a wheel adapter, also known as wheel drum. This wheel drum is under development.

### **Wheel Steering+emergency tiller**

If your boat has an emergency tiller, this can be used to connect the self steering system to. You can actually use the

tiller pointing backwards if that gives an easier layout. When using an e-tiller you do not need a wheel drum.

### **Space on the transom**

You will need space on the transom to bolt the system to. Many boats have a swimming ladder where the self steering system needs to go.

Even though Mister Vee systems offers many more mounting options than most other systems, it is best to fit a self steering system to an empty transom.

Figure out where to put the other bits after mounting the system!

We will gladly advise you on options for combining stuff with your self steering system.

### **Space above the transom**

The windvane needs to stick out above the deck area. If you have a dinghy there or a mizzen boom you will probably find mounting a windvane very difficult.

### **Multi hull's and ULD boats?**

Windvane self steering can not cope with constant acceleration followed by slowing down. This means that it may not be possible to steer an ultra light displacement boat or multi hull.

A windvane self steering system uses the apparent wind direction to keep on course.

When the boat accelerates, the direction changes. The system will correct accordingly which will in the end make the boat slow down.

The course will again be corrected and the cycle restarts.

# Mounting the system

## Requirements

A servo pendulum self steering system needs to be mounted on the boats center line, with the windvane getting the cleanest flow of air, the pendulum rudder a certain depth and the steering lines guided to the tiller or steering wheel.

## Mounting height

A servo pendulum system has to have the pendulum rudder at a certain depth.

With the Mister Vee system this is about 50 cm or 1'8" when the boat is at rest. This determines the height of the mounting. If this height does not suit your transom (which usually means it needs to be lower), the rudder stock can be shortened or a short-blade pendulum rudder is required (option at no extra charge). If you need an extra long pendulum rudder for an extra high transom, this is possible as an option.

When we speak of the mounting height, we mean the axis around which the pendulum swings, which is the top of the pendulum rudder where the gears meet.

This is about 100 mm/4" below where the holes for the upper mounting points are drilled.

If you need this mounting height to be ABOVE where the system connects to the boat, this can be done with some additional parts.



## On the center line

A servo pendulum self steering system needs to be mounted on the boats center line.

If it is mounted off center the pendulum rudder can swing out of the water on one side than the other which may result in a loss of steering power.

## Transom hung rudder

If you want to fit the self steering system around/behind a transom hung rudder, the Mister Vee systems are in a league of their own. Most variants can be fitted, needing only some extra mounting tube. **No need to have a custom mounting frame made!**

The suitability of the variant does depend on the rudders shape: The bigger the rudders head, the further away the system needs to be and, at the same time, it is likely the setup needs to be wider to accommodate the rudders swing from side to side.

There also needs to be enough distance from the rudder and the pendulum rudders tip.

Please contact Mister Vee for advice, and include some pictures of the situation.

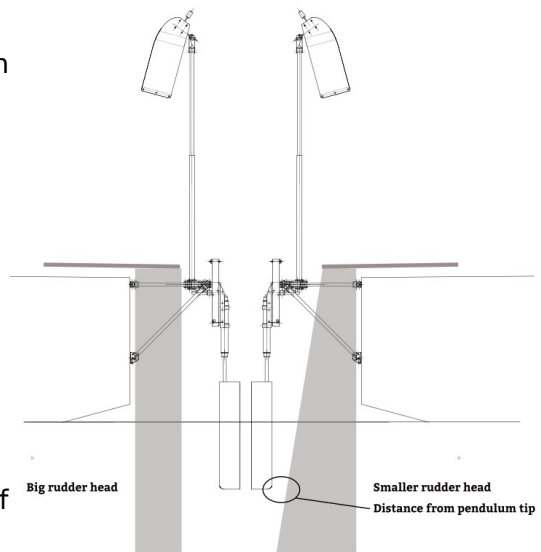

## **Special rudder heads**

Some rudder designs, for instance those often found on double enders, have the rudders axis of rotation going through the rudder head. That may mean that you actually need to connect the steering lines to the rudder head, not the tiller!

## **Outboard engine**

Particular attention needs to be given if you wish to combine self steering with an outboard engine.

It may be possible to do this.

Please contact Mister Vee for advice, and include some pictures of the situation.

## **Swim ladder & other gear**

Mounting a self steering system on the center line can often be a challenge because of other gear that is already there.

Especially boarding ladders are often right where the self steering system needs to go.

It may be very tempting to try and find a way to fit the self steering system around a swim ladder. But the best approach is to remove the ladder and mount the self steering system to an empty transom, and then figure out what to do with the ladder, either by relocating the existing one or actually fitting a different kind of ladder.

## Steering lines

The steering lines are connected to the pendulum rudder and pull the boats main rudder in the direction that results in the desired course corrections.

The shorter the path the lines need to take, the better the response will be. Also, the path that requires the fewest guide blocks is also better than the one that requires more. Generally speaking it is better to connect to a (emergency) tiller than it is to connect to a steering wheel.

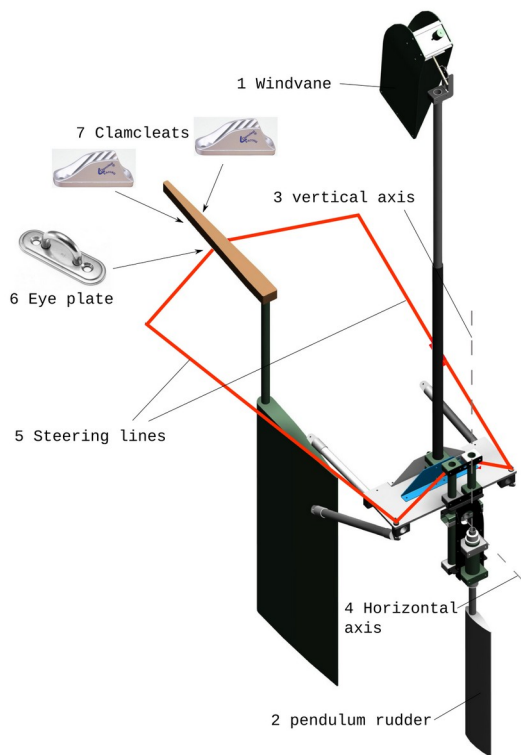



## **Setting up the steering lines**

After the system has been mounted to the transom, you will need to set up the steering lines (not included). The lines are connected to the pendulum rudder and are lead to the tiller or steering wheel. Movement of the pendulum rudder moves the boats main rudder.

This requires at least two guide blocks on either side of the tiller (not included) but some paths require more.

The more blocks you need and the longer the lines are, the more play can get in to the system.

If this gets to extremes, the systems response to changes in wind direction can become slower, resulting in more zig-zagging.

However, this is quite rare.

But for example, on a boat with a center cockpit the lines are long and will probably need many guide blocks.

### **The best results are achieved by:**

- Using the least amount of guide blocks
- Using thin low stretch lines like dyneema/spectra or aramid
- Giving the steering lines the shortest paths.

Because the low stretchlines are generally difficult to knot, it is best to use thin lines in stead of thicker ones. You can go ahead and start with 4 mm WITH SLEEVE, even on bigger boats. Only if that breaks, try thicker ones. Do not use sleeveless dyneema as that cannot be held in the provided cleats.

Most blocks will do but slide bearings are preferred as the loads can be high and movement is small.

## Tiller steering

This is the easiest to set up, even if that is an emergency tiller on a boat with wheel steering. The guide blocks that are needed on the boat are not included with the systems.

The path of the steering lines is more or less free, with these general points:

The fewer blocks you are able to use and the shorter the lines, the smaller the chance of lack of tension in the lines resulting in slow responses to the systems input.

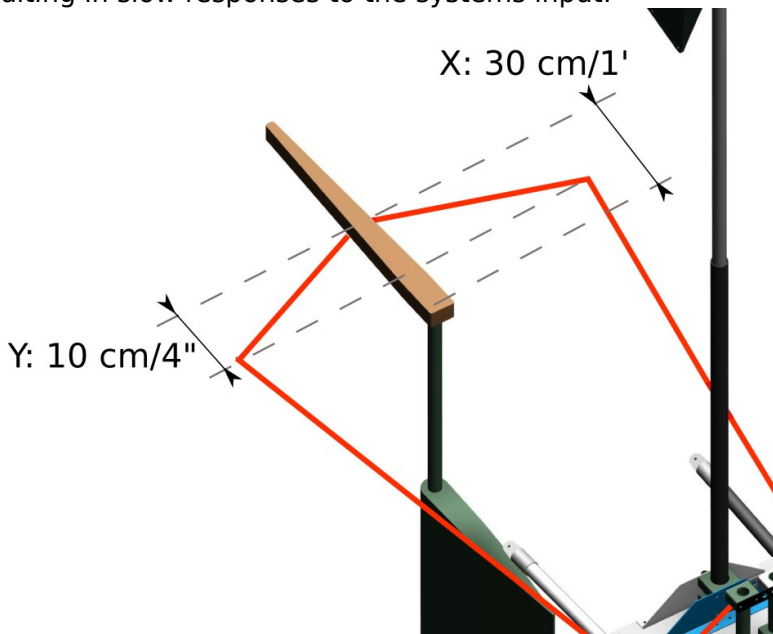

The steering lines connect to a point (Dimension X) about 30 cm/1' from the rudder stock/-hinge for all systems except Mr. Vane (12 cm/5" for Mr. Vane).

The blocks on either side of the tiller need to be a bit (like between 2 and 4") behind (dimension Y) that point (so towards the rear of the boat) and need to allow enough room for the tiller to swing sideways.

It is preferred to have these points below the point where the lines connect to the tiller, otherwise the steering lines may at some point want to lift up the tiller.

The parts to connect the steering lines are included with the system.

### **Alternative path for the steering lines**

Y&B allows for the steering lines to be lead up as well as down. For guiding them up they are connected to the top of the pendulum arm, for guiding them down to the bottom of the pendulum arm.

When connecting the steering lines to the top of the pendulum arm, the starboard line connects to the tiller from starboard.

When connecting the steering lines to the bottom of the pendulum arm, the starboard line connects to the tiller from port-side so the lines need to cross somewhere.

### **Wheel steering**

Wheel steering needs a few more guide blocks to get the steering lines in the correct paths. The most common paths are coming up from the cockpit floor or from the side.

Because of the long lengths of line and great number of guide blocks that would be required for a boat with a center cockpit, using a standard servo pendulum system is not recommended on this kind of boat. These are often better off with an auxiliary rudder type system (not on offer from Mister Vee).

### **Emergency tiller**

If your boat has wheel steering with the option to connect an emergency tiller, this is often easier to set up than wheel steering.

If it is easier to use, the tiller can even point backwards. When used in this way, the steering lines need to connect to the bottom of the pendulum arm, please refer to “Alternative path for the steering lines” in the grey box on the previous page.

### **Mounting in the water or on the hard?**

Mounting your system can be done both on land and with the boat in the water.

Generally speaking it takes the least amount of time with the boat with the stern towards a jetty. You will be stepping on and off the boat quite a bit and that is easiest with the stern towards the dock.

With the boat on the hard the chance of dropping things in the water is nil and you will not spend time or energy on preventing that.

Mounting the system from a dinghy can be done but is not recommended. The dinghy will want to move a lot and if you tie it tight to the boat it will often be in the way of where the system needs to go.

#### **Mister Vee:**

*Your boat may dictate where to connect your self steering system to the transom*

## **Section 3:**

# **Choosing your Mister Vee self steering system**

In essence, choosing your Mister Vee self steering system means choosing how you want or need to mount it.

Mister Vee offer the widest variety of standardized mounting options.

### **Mounting your Mister Vee self steering system**

A windvane self steering system needs to be mounted to the rear of the boat.

Mister Vee aim to provide you with a self steering solution that can be mounted right out of the box:

On any transom type (image further down)

- without having to fabricate complicated custom brackets,
- without having to add heavy and expensive accessories
- without the requirement to have the complete self steering system custom made.

To mount your system you will usually need to connect bolts through the transom.

If your boat has limited access to the inside of the transom, for instance because of other gear on the inside, or just lack of access:

Mister Vee offer mounting systems that allow for the boat to dictate where to drill the holes instead of the self steering system dictating where the holes need to be.

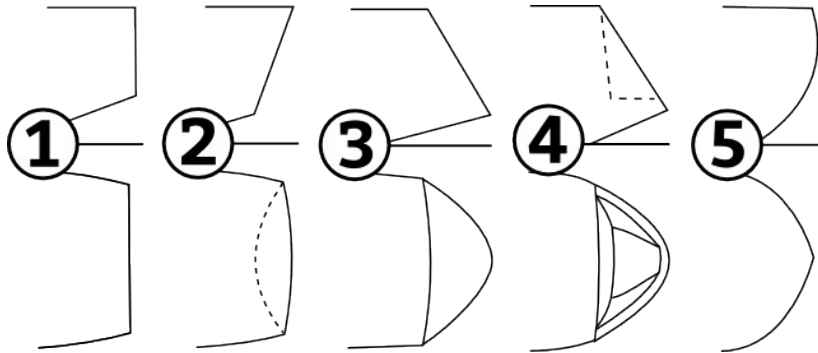

Transom types

## Mounting solutions overview

At the heart of the Mister Vee mounting options we have what we call the Vane base.

This is where the bits that make up the self steering system and the mounting system meet.

For most situations Y&B round 90 or Y&B round 30 will suffice.

And for more challenging situations, we offer alternatives that give more mounting freedom.

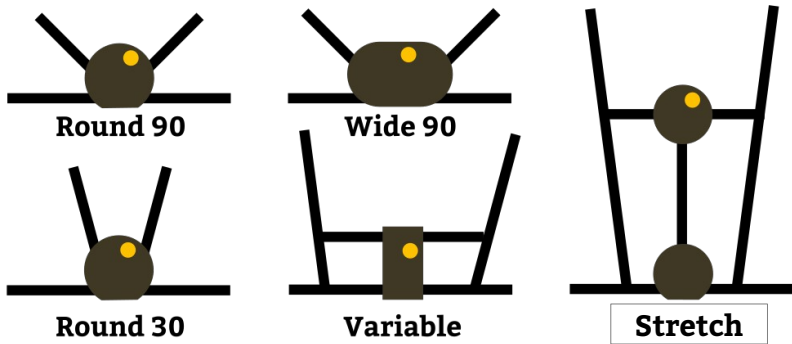

Mister Vee offer Vane bases (pictured above) to adapt to particular mounting challenges:

- Round (30 and 90 degrees standard, and custom angle)
- Wide, a variation of round, (90 degrees standard and custom angle)
- Variable
- Stretch, a variation of variable.

With Round and Wide vane bases, the angle between the upper mounting tubes is fixed at 30 or 90 degrees or a pre determined Custom angle.

With the fixed upper mounting tube angles of Round and Wide the actual mounting process is easier. These mountings also offer the cleanest looks and generally speaking offer the lowest purchase price.

With Variable and Stretch vane bases, the angle between the upper mounting tubes can be chosen during mounting, at 11.25 degree presets or (with a bit of filing) at any angle in between.

This offers great freedom during the mounting process but

in turn this freedom can also lead to a more involved mounting process.

With optional extra parts both Y&B Variable and Y&B Stretch can be mounted extra high, for instance above the deck or above a transom hung rudder/tiller.

### **Length of the mounting tubes**

The Mister Vee systems come with one 145 cm length of carbon fiber mounting tube as standard.

This is cut to length during mounting, to best suit your transom.

Please check if 1 tube is enough, especially for canoe sterns, transom hung rudders and Y&B Stretch, you will likely need more.

The mounting tubes have a diameter of 25 mm.

If damaged during travels, they can be replaced with any kind of 25 mm or 1"(25,4 mm) tube or even a wooden broom handle, as long as the replacement has good wall thickness.

## **3.1 Mister Vee systems comparison**

The diagram on the next page shows which solution is most suitable for your particular situation.

**Green:** Suitable

**Light green:** Generally suitable but another option may prove to be better, please contact Mister Vee for advice.

**Yellow:** Rarely useful but possible to choose this option.

**Red:** Not suitable



	Round 30	Round 90	Wide 90 or CA	Round CA	Variable	Stretch
Vertical (1) Positive (2) and Negative transom (3) , 2 and 3 may need extra mounting tubes	Yes	Yes	Rarely useful	Rarely useful	Rarely useful	Rarely useful
Scoop (4)	Yes, with extra mounting tube	Yes, with extra mounting tube	Yes, with extra mounting tube	Yes, with extra mounting tube	Yes, with extra mounting tube	Yes, with extra mounting tube
Very long scoop (4)	Possible but maybe limited access to windvane	Sometimes possible but maybe limited access to windvane	No	Sometimes possible but maybe limited access to windvane	Yes	Yes
Canoe stern (5)	Yes, with extra mounting tubes	No	Yes, mostly with transom hung rudder	Yes, but with limited benefits	Rarely useful	Rarely useful
Behind and around transom hung rudder	Rarely useful	Yes, please send picture of the rudder AND transom	Yes, for large rudders, please send picture of the rudder AND transom	Yes, please send picture of the rudder AND transom	Yes, please send picture of the rudder	Rarely useful
Above and behind transom hung rudder/Extra high	No	No	No	No	Paid option	Paid option
Far reaching transom hung rudder	No	No	No	No	Maybe limited access to windvane	Yes
Outboard engine on transom	No	No	No	Yes, with off center engine	Yes, with off center engine	Rarely useful
Holes anywhere	Only the lower holes	Only the lower holes	Only the lower holes	Only the lower holes	Yes	Yes

## **Y&B Round 30 & 90: Standard mounting (link)**



Round 90 vane base

The standard round vane base has the upper mounting tubes at 90 degrees (shown here) or 30 degrees and 90 degrees for the Y&B Kit.

The 90 degree angle can be used for mounting around and behind a transom hung rudder and the 30 degree angle may be particularly suitable for mounting on a canoe stern/double ender.

## **Y&B Round CA (link)**

If the 30 or 90 degree upper mounting tube angle does not suit you, the round vane base can also be made with the upper mounting tubes in any custom angle, determined before manufacturing.

This includes extra wide angles and a-symmetric settings, for instance for an off center mounted outboard engine.

## **Y&B Wide 90 & Wide CA**



Wide 90 Vane base

For a mounting around and behind a larger transom hung rudder, or a narrow canoe stern.

The wide vane base allows the system being mounted further forward than with the round vane base but still allowing the rudder to swing completely.

## **y&b round & wide in short:**

Description: Light weight self steering system with pre made angle of Upper mounting tubes

System weight: 10 kgs, including mounting kit

Boat size: any, up to 12 meters, sometimes more

Transom types: All types, with or without transom hung rudder,

Standard mounting height: 1 meter

Options:

- Y&B 90 or Y&B 30, 90 respectively 30 degree upper mounting tube angle (free option)
- Y&B CA (Custom angle, paid option)
- Wide 90 and Wide CA vane base for mounting behind a larger transom hung rudder. (paid option)
- Extra mounting tube for the mounting kit (paid option)
- Short pendulum rudder (mounting height 50 cm) (free option)
- Custom length pendulum rudder (mounting height between 50 cm and 100 cm free option)
- Custom length long pendulum rudder (mounting height higher than 100 cm, paid option).

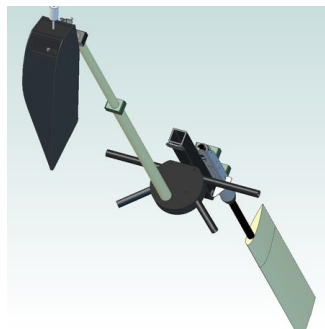

To offer you the best solution for custom angles, please contact Mister Vee.

## [Y&B variable \(link\)](#)

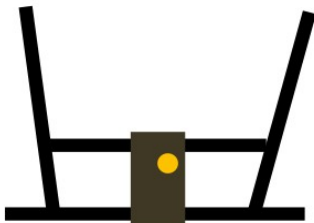

Variable vane base

If the pre-set 30 or 90 degree angle of the upper mounting tubes does not offer the right solution, or you cannot determine the angle you need beforehand, you can opt for the variable mounting.

Thanks to the variable mounting system, Y&B is usable on just about every transom, with or without a transom hung rudder, and even with some off-center outboard engine mountings.

The upper mounting tubes can be set from 0 degrees to 45 degrees on either side (0 to 90 degrees for both sides combined), with a total of 5 steps per side.

If you need an angle in between these steps, the separation between each step can be filed away.

Some mountings require an extra carbon fiber mounting tube for extra distance from the transom.

The mounting kit with Y&B variable allows you to choose the 4 mounting point almost anywhere, giving you ultimate freedom in how to connect your system.

For most transoms that would be a symmetrical mounting but for some an a-symmetrical mounting is the key to success.

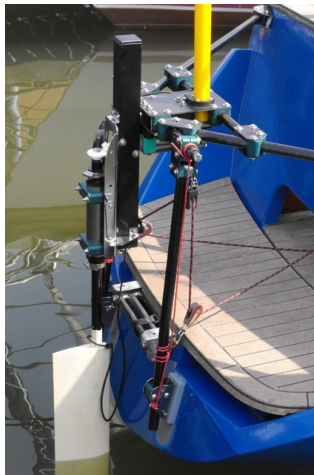

Y&B Variable mounted on a scoop with alternative path for the steering lines

## **Y&B variable in short:**

Description: Light weight self steering system with expanded mounting options

System weight: 10 kgs, including mounting kit

Boat size: any, up to 12 meters, sometimes more

Transom types: All types, with or without transom hung rudder, with or without off center outboard engine

Standard mounting height: 1 meter

Options:

- Extra mounting tube for the mounting kit (paid option)
- Short pendulum rudder (mounting height 50 cm, free option)
- custom length pendulum rudder (mounting height between 50 cm and 100 cm, free option)
- custom length long pendulum rudder (mounting height higher than 100 cm, paid option).



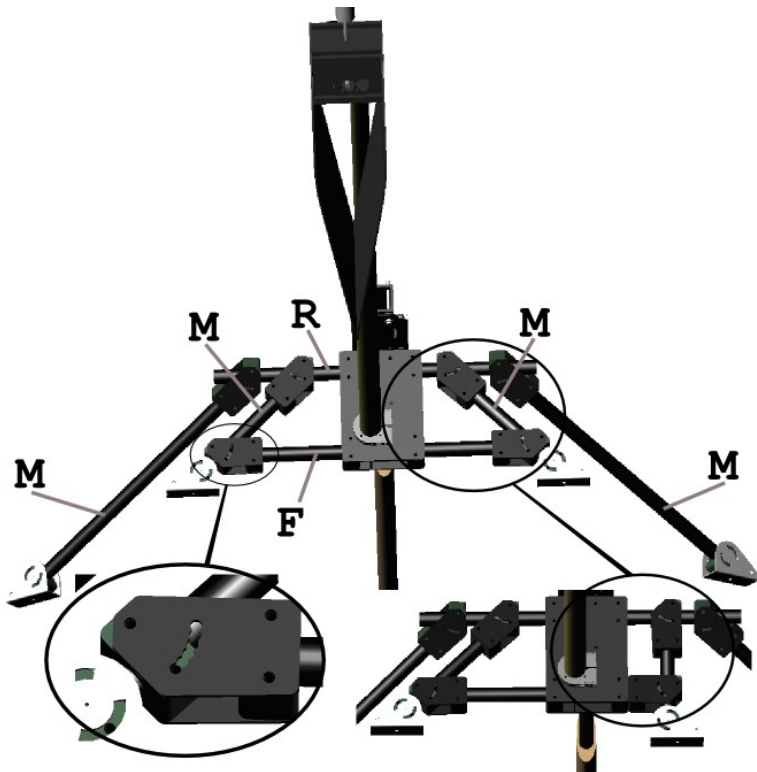

Y&B Variable mounting, bottom right shows a-symmetric setup, Y&B Stretch uses that same system

## [Y&B Stretch \(link\)](#)

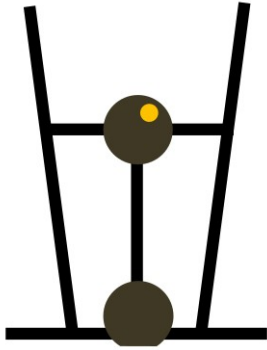

Stretch vane base

If you have a transom hung rudder that extends far behind the rear of your deck, or you have a very long scoop, the windvane and mast could be too far aft to be able to reach it.

For this Mister Vee offer Y&B Stretch, where the distance between the mast and the pendulum rudder has been

increased. This distance is 200 mm with the other systems but with Y&B Stretch it is 500 mm.

If needed, this distance can be optimized to your particular situation.



That will not work, mast too far to the rear...



Have the mast further forward with Y&B Stretch

## Stretch & Up

With the addition of some extra parts, Y&B Stretch can be mounted so that the vane mast is actually above the tiller and can even be in front of the transom and above the deck.

This can also be beneficial in other situations too, please let us know your ideas!

Options:

- Extra mounting tubes for the mounting kit (paid option, usually required)
- Short pendulum rudder (mounting height 50 cm, free option)
- custom length pendulum rudder (mounting height between 50 cm and 100 cm, free option)
- custom length long pendulum rudder (mounting height higher than 100 cm, paid option).
- Mounting with the mast higher up and over for instance the rudder/tiller

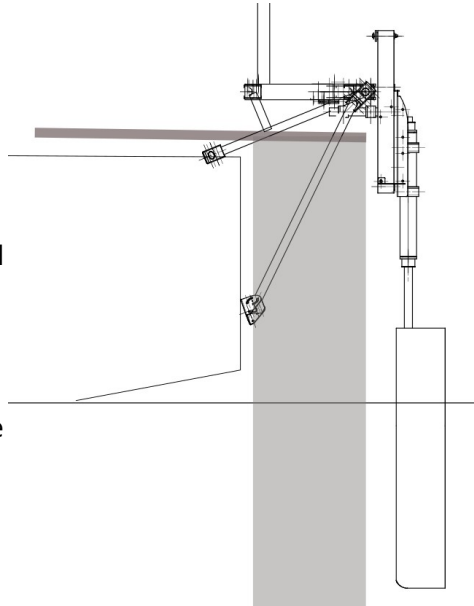



## **Y&B KIT (link)**

Y&B Round 90 is also available as Y&B Kit, aimed at reducing the purchase price as much as possible.

The parts come to you in a rough state, straight from machining, to be finished and assembled by you.

## **Plywood pendulum rudder**

In its most affordable form, the pendulum rudder needs to be built with epoxy, from the supplied plywood and carbon fiber tube. You can shorten the carbon fiber tube to achieve a lower mounting height.



The plywood needs to be shaped by sanding. The shape you need to make is indicated by grooves in the supplied plywood:

The rough edges need to be softened, the stainless steel needs to be passivated with citric acid.

After the rudder has been built, it needs to be painted to protect the epoxy from UV radiation. Some other parts will also need paint at some point in time.

When finished, the system is technically identical to Y&B except for the pendulum rudder blade.

## **Epoxy foam pendulum rudder**

If you prefer, Y&B kit is also available with the standard epoxy foam and glass fiber blade. If a part of the kit, it comes to you straight from the mold, without any finish. So

it needs to be cleaned from mold release, sanding and paint.

### **[Dimensional drawing \(link\)](#)**

There is a drawing with general dimensions of Y&B standard available from the download section of the Mister Vee website.

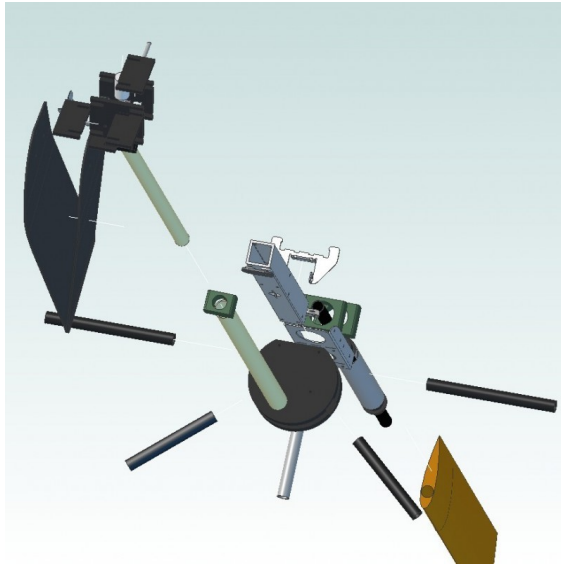

# **Section 4:**

## **Using windvane self steering**



# IMPORTANT

Keep the pendulum rudder tied to the boat at all times!

It represents more than a third of the value of the entire system and it does not float!

Tie the rope around the pendulum rudder stock, making sure that it does not hinder the pendulum swing.

## **Considerations on using self steering**

When using any servo pendulum self-steering system, keep the following in mind:

### **Practice before you really need it**

Some maneuvers may go totally different or a lot quicker in stronger winds than they would in light winds. Always practice in light winds what you later want to rely on in stronger winds!

### **Proper trim**

If you have trouble to steer the boat yourself, so will the system. Take care to properly trim the sails and reduce sail area in time if the wind picks up.

### **Locked windvane equals locked system**

If the windvane is locked by moving the mast slider down, the system will not steer. If the steering lines are connected to the tiller with the windvane locked, the boats rudder is fixed. In order to manually steer the boat the steering lines must be disconnected from the tiller.

## **Moving boat**

The boat must be moving forward for the system to be able to steer.

## **Reversing the boat**

Normally you can reverse the boat with the pendulum rudder in the water. As long as it is not connected to the boats rudder it will not affect the boats handling. The pendulum rudder will move to one side and will stay there as long as the boat keeps going backwards.

### **Important:**

If the upwards swing of the pendulum rudder is limited by some restriction in the steering lines, the pendulum rudder may pull extremely hard, putting a very big load on the steering line and also introducing steering action.

Always: Proceed with caution.

## **Pendulum rudder angle**

With the boat at dock, make sure that the leading edge of the pendulum rudder points straight forward when it is vertical in the water and the windvane is locked in the neutral position. Adjust by reconnecting the pendulum rudder or for fine tuning, adjust the big gear on the pendulum rudder if needed.

## **Counterweight**

For the best light wind performance the windvane must be perfectly balanced:

The counterweight inside the windvane (all systems except DIY WALT) or besides the windvane blade (DIY WALT) balance the weight of the pushrod, the one on top of the

windvane balance the windvane blade. If you reduce the length of the pushrod, the push rod counterweight may need to be reduced in weight.

## Big forces at play

**If you need to do any work on the pendulum rudder while on the water keep the following in mind:**

A servo pendulum is a very powerful apparatus.

It can move in a blink of an eye and combined with the power **can cause serious injury.**

Always **stop the boat** from going forward if you need to have your hands close to or in the area where the pendulum rudder moves and proceed with extreme caution!

--- "Steering like a dream" ---

*The owner of the Kolibri 560, organizer of the small ships race and one of the first customers, telling about his crossing of the North sea from the UK to Holland with gale force winds*



## 4.1 Operating the system

### Before you leave

Always connect the windvane first and the pendulum rudder second!

If you connect the pendulum rudder before the windvane, the pendulum rudder will track out of the boats center line.

### Connecting the pendulum rudder

When you connect the pendulum rudder to the pendulum arm, it probably makes most sense to do so by pushing the pendulum rudder down in the water, making sure the teeth of the big and small gear meet correctly.

This way can only be done when the boat is at rest, it is difficult or even dangerous to do it when you are out on the water.

The boats movement will likely move the pendulum rudder, resulting in movement, in turn generating big forces.

Second method: Downside Up

The pendulum rudder can also be connected pointing up.

To practice this, start with taking the pendulum rudder off when it points up to familiarize yourself with the way it needs to be oriented.

### First trials

When you go sailing for the first time, go when the waves are gentle and the wind is 2-3 beaufort.

Have plenty of space around you and give yourself time to get to know your system.



## Setting course

1. Start with the windvane locked in the neutral position (mast slider down).
2. Lay in the course you want the boat to go, with the sails properly adjusted.
3. Connect the steering lines to the tiller and check if the boat is not steering away from the desired course immediately.
4. With the windvane locked (mast slider down) turn the top part off the vane mast so that the windvane is roughly pointing in to the apparent wind. The wind hits the vane mast first and then the windvane.
5. Unlock the windvane by moving the mast slider up the vane mast. The system starts to steer the boat.

If the windvane swings out immediately, turn the top of vane mast so that windvane resumes neutral position.

If the system steers correctly the windvane should move within + or - 5 to 10 dgs. from neutral, depending on the variation in the wind.

6. If the system steers the boat correctly but the windvane is constantly at an angle with the vane mast, the system probably has to overcome some weather helm.
7. Tighten the steering line so that the boat steers away from the wind a bit more. Repeat if necessary.
8. If the system over steers (steers a zig-zag course), especially on off wind courses, it may help to increase the angle of the windvane axle from the standard 20 dgs (leading edge of windvane parallel to vane mast) to 30-50 dgs. (leading edge of windvane at 10- 30 dgs to vane mast). Do some

experimentation on how much windvane axis angle works best, a few degrees difference can give a big difference in the resulting steering.

Do keep in mind that some combinations of waves and wind direction make it very hard if not impossible for a self steering system to steer to your satisfaction as these courses would require anticipation which a windvane self steering system can not provide. A small change in course can be the best thing to do.

## **Changing course**

### **Changing course without changing tack**

Turn the top of the vane mast to the position needed for the next course. If you want to change to be more than lets say 5-10 degrees you may need to adjust the steering lines.

Usually it works best to make more small changes rather than one big one, adjusting the steering lines gradually.

### **Tacking or gybing**

1. Lock the windvane by sliding the mast slider down
2. Turn the windvane to the position needed for the next course.
3. Disconnect the steering lines
4. Tack or gybe the boat as you normally do.
5. Reconnect the steering lines to the tiller.
6. Adjust the mast and steering lines as described previously.

## 4.2 Routine maintenance

### Loose nuts and bolts

Keep an eye on nuts becoming loose. Tighten if required.

### Bearings

Keeping the ball bearings moving freely is the most important maintenance to keep up the performance of the system. In warm and salty circumstances the bearings may clog up due to salt crystal build up.

Flush with luke warm fresh water daily.

**NEVER use hot water** as that may weaken the epoxy in the tubes

**NEVER use any kind of grease or oil on any of the bearings.** Under the influence of sunlight and (sea)water this will gum up and block the bearing.

### Mast

Starting 2018 the mast is made from unfinished glass/epoxy tubing.

Over time the epoxy may degrade, and start to expose glass fibers.

This can cause skin irritation.

It is advised to paint the tubes to re-seal the surface if this happens.

## **Pendulum rudder blade**

There are four versions of pendulum rudder blades:

- *Glass fiber epoxy/epoxy foam* (All systems starting 2015, except Y&B Kit)
- *Cast Polyurethane/filler blend* (Y&B and Walt BYO models from 2012 to 2014 and Mr. Vane from 2013 & 2014)
- *Cast Polyurethane foam* (Y&B and Walt BYO models from 2011)
- *Plywood* (All models models before 2011 and Y&B KIT starting 2021)

**Degradation from poor waterproofing is not covered by warranty so keep the following in mind:**

### **Glass/epoxy version**

Epoxy is highly waterproof but has no resistance against Ultra Violet radiation, therefore the rudder blade needs to be painted.

Any waterproof paint will do and most will stick to the epoxy without problem.

### **Plywood version**

The plywood version needs to be coated with a suitable under water coating system to prevent water ingress.

Carefully examine the blade for cracks appearing in the coating that you have applied.

If you see any cracks, sand those areas smooth and re-coat them to prevent the cracks from opening and admitting water.

### **Polyurethane versions**

So far it seems that the PU pendulum rudder can stand being submerged in water for prolonged times. HOWEVER, if you plan to have it submerged continuously, like for multi day sailing, also coat the rudder blade with a suitable under water coating system.

### **Steering lines**

Keep an eye on potential wear on steering lines and its surroundings.

### **Cleaning the system**

If you want to clean the system, best use fresh water and a cloth, sponge or soft brush with some mild soap. NEVER use abrasive materials on the glass fiber and carbon fiber as this may eventually expose the fibers and induce rapid deterioration.

The tubes can be painted if desired/needed.

# 4.3 Trouble shooting

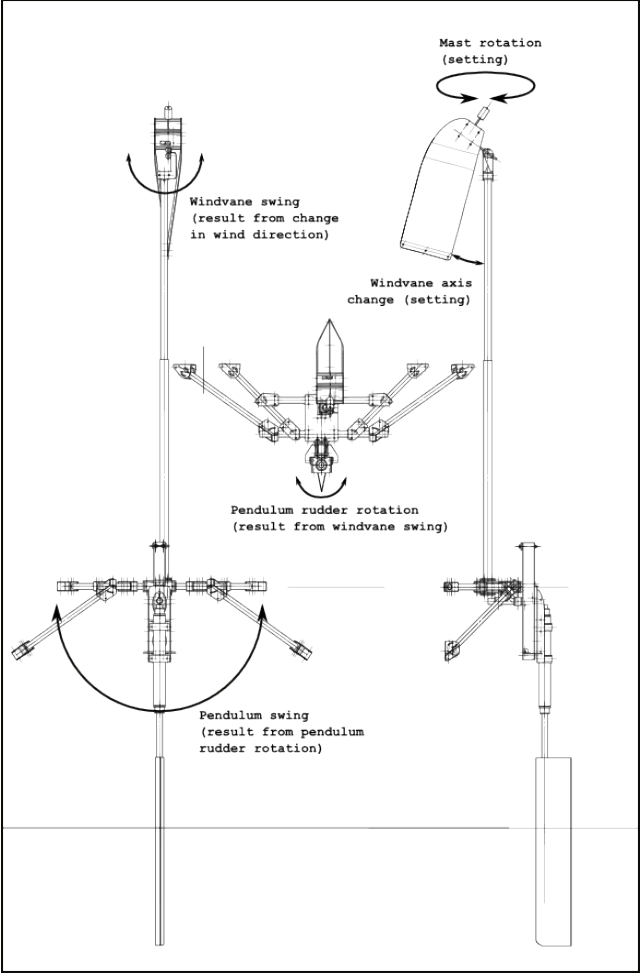

## **The terms we use when trouble shooting**

### **Mast rotation**

This is where you set the course. In this drawing the course is set for wind from behind .

### **Windvane axis change**

This setting changes the sensitivity with which the system responds to changes in wind direction.

The change you can make is from 0 degrees to about 30 degrees.

When you change this setting you actually change the angle to horizontal around which the windvane rotates. This axis is set at 20 degrees off horizontal when windvane axis change is 0 degrees and with newer systems is limited to 50 degrees, at which point windvane axis change is 30 degrees.

Systems prior to 2013 can have a change applied up to 70 degrees, at which point the windvane axle is upright. At that setting the system would no longer steer.

In the drawing the angle has been changed to 30 degrees.

### **Windvane swing**

This is the result of a change in apparent wind direction.

It is mechanically limited to roughly 55 degrees to either side.

### **Pendulum rudder rotation**

This is the result of the windvane swing.

The AMOUNT of pendulum rudder rotation depends on windvane axis change.

The more Windvane axis change has been applied, the smaller the pendulum rotation becomes.

## **Pendulum swing**

This is the result of the Pendulum rudder rotation.

When the Pendulum rudder rotation starts, the pendulum immediately starts to swing out.

The further the pendulum swings, the smaller the pendulum rudder rotation becomes.

## **Problems and solutions**

### **The boat steers a zig-zag course (oversteering)**

#### **Off wind course**

An off wind course is the most difficult for most self steering systems, especially in waves.

Going down a wave usually changes the boats course which makes the apparent wind direction change which results in a reaction.

First, increase the windvane angle change from 0 to 30 degrees and then play with this setting to fine tune.

Especially on off wind courses a small change here can have a big impact on course stability.

Do keep in mind that you at some point you may experience a combination of wind (direction) and waves that are impossible for a windvane system to handle. These are the courses where you would anticipate the boats movement and steer accordingly before the boat goes off course.

If you experience zig-zagging with little wind, check for friction in the system.



If there is no internal friction it may help to increase the angle of the windvane axis from 20 dgs (leading edge of the windvane blade parallel to the mast) to high angles (leading edge of windvane at 10-15 dgs to vane mast).

This may help especially on courses with the wind between 90 degrees (side wind) and 180 degrees (running course).

When you increase the angle, the travel gradually decreases.

Connection point of the steering lines on the tiller

It may also be the case that the boat moving down waves causes a change in direction that can not be corrected quickly enough.

This may be solved by moving the connection point closer to the boats rudder stock/hinges. See "pendulum rudder stays at the surface" for more details.

Internal friction

Check if the windvane moves freely and smoothly. If it jerks there is probably friction in the path between the windvane and the vertical rotation of the pendulum rudder.

If there is no friction in the system, check the rudder arrangement for friction too.

### **Friction may occur in these points:**

Check these items in this sequence:

#### **Windvane**

M8 axle

The 4 nuts that fix the ball bearing on the axle may be too tight.

Over tightening may result in the core of the bearing expanding resulting in a bearing that does not move freely.

### **Pushrod axle**

Apart from the core of a ball bearing expanding too much, the bearings that carry the pushrod axle may have their cores forced inward or outward along the m6 threaded rod.

Undo the nuts on one ball bearing, then gently re-tighten, continuously checking if the friction increases.

there should be hardly any difference in friction between the axle with untightened nuts and with tightened nuts.

### **Gear axle/fork touching the vanebase or bearing carrier**

Undo the nut/bolt that hold the gearaxle lever on the gearaxle.

Slide the gear axle lever on the gear axle by 1 mm.

Redo the nut and bolt.

### **The pendulum bearings are too tight**

Check out the video at the customer download section of the main website.

### **The two gears are too tight**

Undo the big green tube clamps that connect the outer pendulum bearing tube to the pendulum bracket.

Slide the pendulum bearing tube down (maybe 0.5 mm is all that is needed!) and redo the tube clamps.

It is ok to have a hint of play between the two gears.

### **Pendulum rudder stays at the waters surface/does not go down**

#### **On windward courses:**

The system steers for a while but at some point the windvane stays swung outwards with the pendulum rudder

remaining at the water surface, the system no longer steers.

**Both tacks:**

If this happens on both tacks, the point where the steering lines connect to the tiller may be too far forward from the boats rudders axis of rotation. The distance from the rudders hinges/rudder shaft to the connection point should be roughly 250-350 mm (100-250 mm for Mr. Vane).

**Single tack:**

Did you mount the gear axle swing inhibitor (Mr. Vane only)? Please contact Mister Vee.

Did you shorten the length of the pushrod or was the weight of the pushrod changed in another way? (All systems)

This has changed the weight of the pushrod and requires re-balancing of the windvane.

Reduce the number of washers inside the windvane (or on the side with DIY WALT) so it equals the weight of the pushrod.

If you experience this on other than windward courses, please contact Mister Vee for advise.

**Pendulum rudder flotation**

Some of the mountings of Y&B with a polyurethane pendulum rudder have a particular problem with how the pendulum rudder floats when it is at the waters surface.

If you think that flotation is part of a problem you are experiencing, please contact Mister Vee and **include a picture of your mounting with the rudder attached and floating.**

## **The boat is constantly turning slowly in to the wind**

If you have the vane mast mounted off center (Mr. Vane, f.i. for the outboard engine) the windvane may have a smaller angle of attack because of the airflow leaving the mainsail. You will note a big difference in the angle the wind indicator at the top of the mast compared to the angle of the windvane.

Turn the windvane so that the system steers away from the wind a bit more to increase the angle of attack.

This will normally only happen on one tack.

If this remains a problem for a long time it may help to shorten the length of the vane mast (and the pushrod!) so that the windvane drops beneath the airflow leaving the main sail. Please contact Mister Vee for advice before proceeding.

## **Pendulum tracking: The pendulum rudder is not in neutral when the boat is moving forward**

The boat is moving forward, the windvane is in neutral position (locked or able to move) and the steering lines are not connected to the rudder.

The pendulum rudder should be in neutral position but is actually swung out.

This can be caused by:

One or more connections has slipped and/or needs adjusting:

between the top-and bottom part of the vane mast between the gear axle lever and the gear axle between the big gear and the pendulum rudder in the pushrod

Slipping of connections as a result of abnormal forces (like the pendulum rudder touching another boat) should only be corrected, do not tighten the connections further.

First, check to see if the gear axle lever is horizontal when the windvane is in neutral position. With Mr. Vane, the bearing carrier has notches to act as a reference.

If the gear axle lever is not horizontal, adjust the length of the vane mast.

### **Pendulum tracking & Propwash during motoring**

Prop wash may push the pendulumrudder a bit sideways. Disengage the drive and check if the pendulum rudder returns to neutral the propeller turning.

This sideways push is not a problem.

Otherwise the leading edge of the pendulumrudder is not pointing forward when the pendulumrudder is in neutral position. This will cause the pendulum rudder to swing out when the boat is moving forward.

Lock the windvane by moving the mast slider down the mast.

### **Readjusting the pendulum rudder to track better**

Make sure the boat is not moving.

Disconnect the pendulum rudder from the KUM bracket and reconnect it towards the neutral position so that the big plastic gear moves by one tooth relative to the small gear.

If this over-corrects so that the pendulum rudder now stays off neutral to the other side, adjust the big gear on the top of pendulum rudder by half a tooth.

OR

Loosen the connection of the gear axle lever on the inner gear axle and adjust the rotation of the inner gear axle, then tighten the gear axle lever.

### **Still not tracking?**

If this situation occurs AFTER it has been corrected, the following may be the case:

The gears are too loose, check the tightness of the gear axle lever on the gear axle and the bolt that holds the big gear to the pendulum rudder.

If this is ok, this may be the case:

The two gears are not close enough together so they can “jump teeth”. Loosen the big green tubeclamps that hold the pendulum bearing tube and move the pendulum rudder a tiny bit upwards, taking care that the contact between the gears does not get too big!

See the assembly manual for further reference.

### **The windvane is not neutral whilst steering**

This is not so much a problem but more of a tweaking issue.

Disconnect the steering lines and steer the boat so that the windvane is in the neutral position.

Reconnect the lines.

Repeat if necessary.

In general this is needed to counteract a bit of weather helm.

## **Altered pushrod**

If you have changed the length of the pushrod, you probably have taken off enough material to alter the total weight. In that case you probably need to reduce the number of washers in the pushrod-counterweight inside the windvane-head.

If you made changes to the pushrod that have increased its weight, you will need to add weight to the pushrod-counterweight

The pushrod-counterweight needs to have the same weight as the pushrod to optimally balance the weight of the pushrod but small differences are often no problem.

## **The pendulum rudder keeps separating from the system**

The system that connects the pendulum rudder to the rest of the system also provides protection against being overloaded, for instance being struck by something in the water.

The only way to properly set the release force is to start with a very low force and increase it if the pendulum rudder releases too often.

Adjust the screws if it is too loose.

A little extra friction in closing the levers results in substantial extra release force, tighten the screws very gently, by the smallest amount you can!



# **Mister Vee Windvane self steering**

*Freedom with a Vee*

[www.windvaneselfsteering.com](http://www.windvaneselfsteering.com)